

related test method

EN 1634-1 Fire Resistance tests for door and shutter assemblies - Part 1: Fire doors and shutters

subject

Definition of gaps and measurement of size of gaps which contain a 'flexible or moveable seal' in the gap between the door leaf and the door frame

reference of original query

TC2 N307rev1 Helpdesk 2003-02

Problem

Before the test, the laboratory must measure the gaps around the door leaf. In some cases the door may contain a 'flexible or moveable seal' totally or partially filling the gap between the door leaf and the door frame [see figures below].

The standard is unclear about how to define the gap in this case and how to measure it. If the normal gap measuring method is attempted it is very difficult to take the required measurements because of interference with the measurement by the seal.

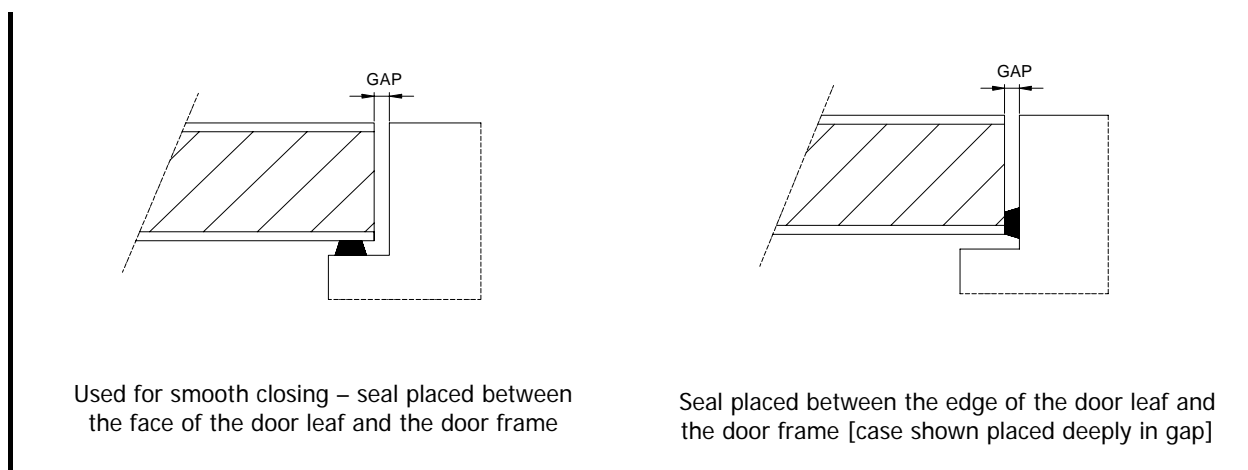

Recommendation

Each gap shall be defined as the distance (in the cold situation) between any 'non-flexible' components of the door leaf and the door frame.



In this context seals are 'flexible' in nature and have the job of filling the gap by compression, deflection or movement in the cold situation.

The gap dimensions shall be taken as the dimensions disregarding any flexible seal (a seal which is compressible or deflectable) or movable seal.

When a door contains flexible or moveable seals the gaps shall be measured as follows:

- directly after removal of some part of the seal
- indirectly, e.g. by drawing lines (as shown below):

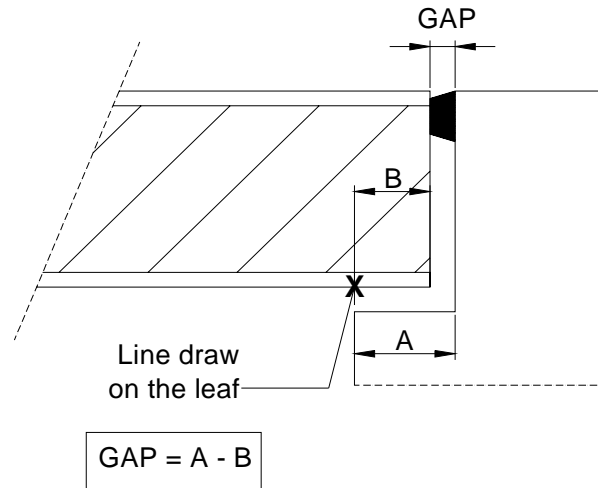

In addition:

1. The geometry of all gaps between the door leaf and the door frame shall be fully described in the test report.
2. The gaps shall be measured along each side of each door leaf (i.e. leading leaf edge to frame, hinged leaf edge to frame, leaf top edge to frame, leaf bottom edge to frame/sill etc.).
3. The nature of the seals shall be fully described (material, geometry etc.) in the test report.