

Fire resistance tests for cavity barriers

Contents

		Page
	Introduction	2
1	Scope	3
2	Normative references	3
3	Definitions	3
4	Test equipment	4
5	Test conditions	4
6	Test specimen	4
7	Installation of test specimen	6
8	Conditioning	6
9	Application of instrumentation	7
10	Test procedure	8
11	Performance criteria	9
12	Test report	9
13	Direct application of the test results	9
Annex A	Cavity barriers under floor voids	11
Annex B	Cavity barriers within walls e.g. masonry leaves	13



Introduction

This European Standard has been prepared by EGOLF Technical Committee 2 (Fire Resistance) in response to a request from EOTA. The test method is needed in support of an ETAG for cavity barriers.

The purpose of this test is to measure the ability of a representative specimen of a cavity barrier to resist the spread of fire from one side to another. A representative sample of a cavity barrier is exposed to a specified regime of heating and pressure. The performance of the test specimen is monitored on the basis of criteria in EN 1363-1. The fire resistance of the tested construction is expressed as the time for which the appropriate criteria have been satisfied.

Caution

The attention of all persons concerned with managing and carrying out this fire resistance test, is drawn to the fact that fire testing may be hazardous and that there is a possibility that toxic and/or harmful smoke and gases may be evolved during the test. Mechanical and operation hazards may also arise during the construction of the test elements or structures, their testing and disposal of test residues.

An assessment of all potential hazards and risks to health shall be made and safety precautions shall be identified and provided. Written safety instructions shall be issued. Appropriate training shall be given to relevant personnel. Laboratory personnel shall ensure that they follow written safety instructions at all times.

1 Scope

This test method specifies a method for determining the fire resistance of cavity barriers and is to be used in conjunction with EN 1363-1.

This standard is applicable to non-loadbearing vertically or horizontally oriented cavity barriers, which are used to provide fire separation to non-compartmented spaces. Cavity barriers are specifically designed to provide a separating function only, which is why they do not resemble walls or undertake the same function. They may be insulating or non-insulating. Typical uses of cavity barriers are: between leaves of masonry walls to prevent vertical or horizontal fire spread through walls, underneath raised access floors to prevent horizontal fire spread in the floor void and above suspended ceilings/loft spaces to prevent horizontal fire spread.

This standard is not applicable to cavity barriers containing penetration seals incorporated into cavity barriers. These shall be tested to prEN 1366-3.

This standard is not applicable to horizontal cavity barriers in e.g. rain screen cladding because it is difficult if not impossible to model the correct thermal exposure and boundary conditions in a fire resistance type test. Such tests should be considered as part of a facades test.

2 Normative references

This European Standard incorporates by dated or undated reference, provisions from other publications. These normative references are cited at the appropriate places in the text and the publications are listed hereafter. For dated references, subsequent amendments to or revisions of any of these publications apply to this European Standard only when incorporated in it by amendment or revision. For undated references the latest edition of the publication referred to applies (including amendments).

EN 1363-1, *Fire resistance tests — Part 1: General requirements*

EN 1366-3, *Fire resistance tests for service installations – Part 3: Penetration seals*

EN 1366-4, *Fire resistance tests for service installations – Part 4: Linear gap seals*

EN 1366-6, *Fire resistance tests for service installations – Part 6: Raised access floors and hollow floors*

EN ISO 13943:2000, *Fire safety — Vocabulary*

3 Definitions

For the purpose of this part of EN 1364 the definitions given in EN 1363-1 and EN ISO 13943, together with the following, apply:

3.1 concealed space

A space in a building where fire may develop or pass through that is not normally used or accessible by humans.

3.2 cavity barrier

A non-loadbearing vertically or horizontally oriented element designed to provide fire separation in a concealed space (cavity).

3.3 splice

A connection or junction between or within the length of a cavity barrier.

4 Test equipment

In addition to the test equipment specified in EN 1363-1 the following is required:

A test frame shall be provided, the rigidity of which shall be evaluated by applying an expansion force within the frame at mid-way between two opposite members of the frame, and measuring the increase in the internal dimensions at these positions. This evaluation shall be conducted in both directions of the frame and the increase of the internal dimension shall be measured.

The increase in the internal dimensions of the test frame shall not exceed 5 mm with an applied force of 25 kN.

5 Test conditions

5.1 Heating conditions

The heating conditions and the furnace atmosphere shall conform to those given in EN 1363-1 and if applicable EN 1366-6.

5.2 Pressure conditions

For cavity barriers mounted between the leaves of walls and above suspended ceilings/in loft spaces, the pressure conditions and the furnace atmosphere shall conform to those given in EN 1363-1

For cavity barriers mounted underneath raised access floors, the following pressure conditions shall apply:

For plenum heights not greater than 1 m, the pressure in the furnace 100 mm below the soffit shall be maintained at + 5 Pa (± 3 Pa) relative to outside the furnace.

For plenum heights greater than 1m, the pressure in the furnace 100mm below the soffit shall be maintained at ± 3 Pa of a pressure calculated as follows:

$$p = 8.5 h - 3.5$$

where: p = pressure in Pa

h = height of plenum below the raised floor in m

The pressure calculated for plenum heights greater than 1m shall be subject to any limitation on overall furnace pressure given in EN 1363-1

6 Test specimen

6.1 Size

If, in practice, the height or width of the construction is 3m or smaller, then that dimension of the test specimen shall be tested at full size. If any dimension of the construction is greater than 3m, then that dimension shall be tested at not less than 3m.

6.2 Number

The number of test specimens shall be as given in EN 1363-1. However, where information is required under different boundary/exposure conditions or where an asymmetrical construction is to be evaluated, additional tests shall be undertaken for each situation using separate test specimens. Where a cavity barrier is intended for use in both horizontal and vertical separating elements, each orientation shall be tested.

6.3 Design

6.3.1 General

The test specimen shall be fully representative of the construction used in practice. More than one type of cavity barrier system may be included in a single test specimen provided the requirements on space separation and thermal and pressure conditions are met.

Joints or splices for the purposes of erection, construction or expansion, shall be incorporated in the test specimen. Different jointing systems or splices may be included in a single test specimen provided that they are both subjected to furnace pressure conditions equal to or greater than those specified in 5.2.

The design features which influence fire performance should be included to give the widest application can be derived from the field of direct application, clause 13.

6.3.2 Test configuration

Three test configurations appropriate to the end uses of cavity barriers are considered in this document:

1. Above suspended ceilings and in lofts to prevent horizontal fire spread.
2. Below raised access floors between the underside of the raised floor and the upper side of the structural floor slab. Special considerations for testing these are given in annex A.
3. Fire stopping between leaves of e.g. masonry walls to prevent vertical or horizontal fire spread between the leaves. Special considerations for testing these are given in annex B.

6.3.3 Boundary/restraint conditions

The test specimen shall be installed with boundary and restraint conditions as found in practice. In most cases cavity barriers are fixed on all edges, in which case any framing and/or material shall be tightly fitted to the test frame, furnace walls or associated construction (as appropriate), without any gap, to ensure that the interaction between the cavity barrier and the supporting construction is fully evaluated.

Where, in practice the width of the construction is larger than the front opening of the furnace, one vertical edge shall be left unrestrained and there shall be a gap of 25mm to 50mm between the free edge of the test specimen and the test frame. This gap shall be packed with a resilient non-combustible material, e.g. mineral fibre with a melting point of at least 1000°C, to provide a seal without restricting freedom of movement. The remaining edges shall be restrained as in practice.

6.3.4 Penetrating services

In some cases pipes, cables or other services may pass through a cavity barrier. In this case, the cavity barrier shall be treated as a penetration sealing system and it shall be tested to prEN 1366-3.

6.4 Construction

The test specimen shall be constructed as described in EN 1363-1.

6.5 Verification

Verification of the test specimen shall be carried out as described in EN 1363-1.

7 Installation of test specimen

7.1 General

The test specimen shall be installed in the test frame and, if used, the supporting construction, as in practice. Any supporting construction shall have a fire resistance performance commensurate with the cavity barrier being tested.

The whole area of the test construction shall be exposed to the heating conditions.

7.2 Standard supporting construction

If the size of the test specimen is smaller than the opening in the test frame then it shall be installed in the test frame using one of the following approaches:

7.2.1 Vertical test specimens

- a) Where the height of the test specimen is smaller than the height of the test frame opening, then a plinth shall be provided to reduce the opening to the required height. The plinth shall possess sufficient stability for the test specimen and shall be selected from one of the rigid standard supporting constructions in EN 1363-1. For vertically oriented test specimens, the joints shall be tested in the upper quarter of the specimen.
- b) Where the width of the test specimen is smaller, a standard supporting construction shall be provided on the vertical sides of the opening selected from either the rigid or flexible standard supporting constructions given in EN 1363-1.

7.2.2 Horizontal test specimens

Where the area of the test specimen is smaller than the area of the test frame opening, then the furnace opening shall be reduced to the area of the test specimen using a suitable construction. In the absence of horizontal standard supporting construction in EN 1363-1, gas concrete or dense concrete slabs shall be used for horizontal specimens.

7.3 Non-standard supporting construction

If the test specimen is mounted in a supporting construction not given in EN 1363-1 or described in 7.2.2, then the result will only be valid for cavity barriers mounted in the construction as tested.

8 Conditioning

The test specimen shall be conditioned in accordance with EN 1363-1.

9 Application of instrumentation

9.1 Thermocouples

9.1.1 Furnace thermocouples (plate thermometers)

Plate thermometers shall be provided in accordance with EN 1363-1. There shall be at least one for every 1,5 m² of the exposed surface area of the test construction. For test specimens with less than 6 m² exposed surface area a minimum of four plate thermometers shall be used.

For vertical test constructions, the plate thermometers shall be oriented so that side 'A' faces the walls of the furnace opposite the test construction being evaluated.

For horizontally oriented test constructions, side 'A' of the plate thermometers positioned below the test construction being evaluated shall face the floor of the furnace.

9.1.2 Unexposed surface thermocouples

9.1.2.1 General

Surface thermocouples of the type prescribed in EN 1363-1 shall be attached to the unexposed surface of the test specimen to measure the average and maximum temperature rise. For the location and number of these thermocouples refer to EN 1363-1.

Specific rules for evaluating the unexposed face temperature of cavity barriers mounted with the leaves of walls are given in Annex B.

9.1.2.2 Thermocouples for measuring the average temperature rise

- a) Where the total area of a cavity barrier is $\leq 0,25$ m² it shall be disregarded for the purpose of determining the average unexposed face temperature. In this case only thermocouples for measuring average unexposed face temperature rise shall be attached.
- b) The average temperature rise shall be measured with five thermocouples in positions specified in EN 1363-1, i.e. located at, or immediately near, the centre of the test specimen and at, or immediately near, the centre of each quarter section.
- c) When the test specimen has insulated parts with different thicknesses, the number of thermocouples on the unexposed face shall be increased to six to provide equal numbers of thermocouples at the maximum and minimum thicknesses.

9.1.2.3 Thermocouples for measuring the maximum temperature rise

Additional thermocouples shall be attached to measure the maximum temperature rise at locations where higher temperature conditions are expected to exist, on locations in accordance with EN 1363-1 and with a minimum of two per feature.

Locations for vertically oriented cavity barriers above suspended ceilings and/or in loft spaces are given below. Locations for cavity barriers under raised access floors and between the leaves of walls are given in Annexes A and B respectively.

- a. At the head of the specimen at mid-width.
- b. At the head of the specimen in line with a framing member (if present)

- c. At the junction of a horizontal and vertical framing member (if present)
- d. At mid height on the fixed edge.
- e. At mid height of the free edge, 100 mm in from the edge (if present)
- f. At mid width, where possible, adjacent to a horizontal joint (if present) (positive pressure zone).
- g. At mid height, where possible, adjacent to a vertical joint (if present)

9.1.2.4 Roving thermocouple

The information obtained on unexposed face surface temperatures shall be supplemented by additional data derived from measurements obtained using a roving thermocouple applied to identify any local "hot spots" in accordance with EN 1363-1. If it is determined that the roving thermocouple may damage the test specimen, it shall not be used and the reason noted in the test report.

9.2 Pressure

The furnace pressure shall be measured at locations with pressure sensors as prescribed in EN 1363-1 and in clause 5.2 of this method.

9.3 Deflection

Deflection measurements are only applicable to cavity barriers mounted above suspended ceilings and in ceiling voids.

Appropriate instrumentation shall be used to record all significant deflection (i.e. greater than 5 mm) of the test specimen during the test.

Measurements shall be made at the centre of the specimen and at mid-height, 50 mm in from the free edge. The interval of measurement shall be adequate to present a history of movement during the test.

Guidance on the application of deflection measurement is given in EN 1363-1.

NOTE. Measurement of deflection is a mandatory requirement although there are no performance criteria associated with it. The deflection of the test specimen may be important in determining the extended field of application of the test result."

10 Test procedure

10.1 General

The test shall be carried out using the equipment and procedure specified in EN 1363-1.

10.2 Furnace control

Measure and control furnace temperature and pressure in accordance with EN 1363-1.

10.3 Observations during the test

Monitor the test specimen and make observations of the behaviour in accordance with EN 1363-1.

10.4 Termination of test

Terminate the test for one or more of the reasons given in EN 1363-1.

11 Performance criteria

The criteria by which the performance of the specimen is judged by are given in EN 1363-1.

For cavity barriers used as fire stopping between leaves of e.g. masonry walls (see Annex B) the following exceptions apply:

- only the maximum insulation criteria shall be used for evaluating insulation
- only the cotton pad and sustained flaming shall be used for evaluating integrity (i.e. the gap gauge shall not be used).

12 Test report

The test report shall include all the items required by EN 1363-1 as appropriate.

13 Direct application of the test results

13.1 General

The results of the fire test are directly applicable to similar constructions where one or more of the changes listed below are made:

- a) Decrease in:
 - height for vertically oriented cavity barriers within walls
 - length for oriented cavity barriers within floors
- b) Increase in the thickness of the cavity barrier
- c) Increase in the thickness of component materials
- d) Decrease in linear dimensions of boards or panels (if used) but not thickness
- e) Decrease in spacing of framing members
- f) Decrease in distance of fixing centres
- g) Increase in the number of horizontal joints of the type tested. For vertically oriented test specimens, the joint must be tested in the upper quarter of the specimen
- h) Increase in the number of vertical joints, of the type tested, when tested with one joint not more than 500mm from the fixed edge (vertical test specimens only)

13.2 Extension of width

The width of an identical construction may be increased if the specimen was tested at a minimum of nominally 3 m wide with one vertical edge without restraint. In the case of reduced size furnaces, no extension of width is possible.

13.3 Extension of height

The height of constructions tested at a minimum of 3 m, may be increased as follows::

For rigid cavity barriers mounted above suspended ceilings/in loft spaces the height of constructions tested at a minimum of 3 m, may be increased to 4 m with the following conditions:

- a) if the maximum lateral deflection of the test specimen was not in excess of 100 mm (see 9.3)
- b) the expansion allowances are increased pro-rata.

13.4 Supporting constructions

13.4.1 Standard supporting constructions – vertical test specimens

The result of a test of a vertically oriented cavity barrier tested in one of the standard supporting constructions given in EN 1363-1, or the test frame, is applicable to any other supporting construction within the same type (rigid, low density rigid or flexible) that has a greater fire resistance (thicker, denser, more layers of boards, as appropriate).

13.4.2 Supporting constructions – horizontal test specimens

The result of a test of a horizontally oriented cavity barrier tested in a supporting construction as given in clause 7.2 or the test frame, is applicable to any other supporting construction within the same type that has a greater fire resistance (thicker, denser, more layers of boards, as appropriate).

Annex A - Cavity barriers under floor voids

A.1 Introduction

One of the roles of cavity barriers is to prevent the spread of fire in under floor voids. This is particularly important where e.g. there is a raised floor with a fire resisting partition on top of it, but no vertical separation below the raised floor. In these cases, it is possible for fire to spread under the partition in the floor void and bypass the compartmentation.

The conventional approach to this is to provide some kind of fire barrier (cavity barrier) underneath the raised floor in line with the partition. In this way, horizontal compartmentation is maintained.

There are some issues to address when testing such constructions and these are dealt with in this annex.

A.2 Configuration

A suggested test configuration is given below for a mineral wool cavity barrier underneath a raised access floor. Usually in these cases, the height of the barrier is less than 600mm.

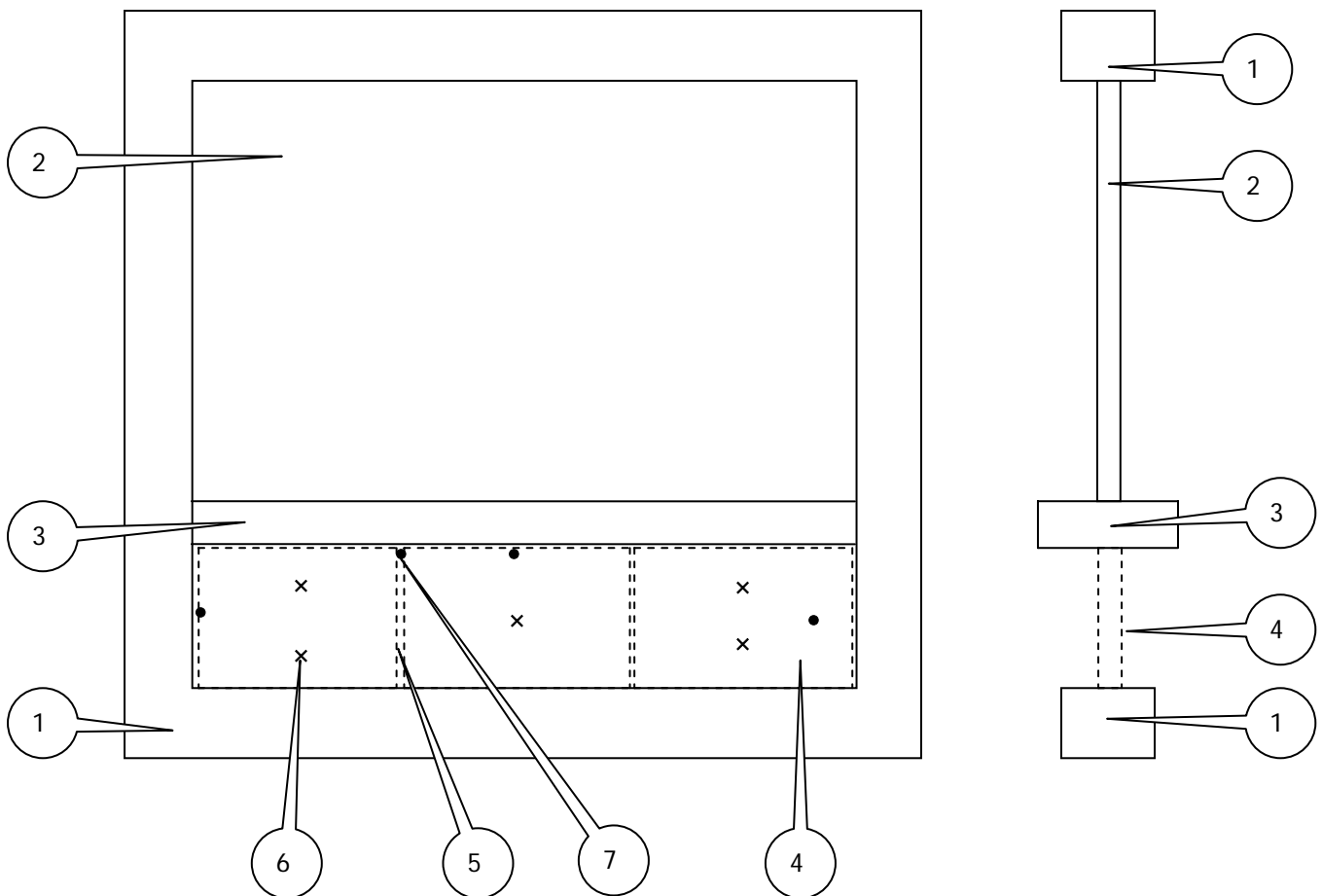

Figure 1 - test configuration for cavity barriers under raised floors

Key to Figure 1

- 1 Test frame
- 2 Furnace closure representing partition (could actually use a partition)
- 3 Gas concrete slab (fixed to test frame) representing raised floor
- 4 Test specimen (cavity barrier)
- 5 Joint in specimen
- 6 Thermocouple positions for average temperature rise
- 7 Thermocouple positions for maximum temperature rise

A.3 Thermocouples for measuring the maximum temperature rise

Additional thermocouples for measuring maximum temperature rise shall be included at the following locations:

- a. At the head of the specimen at mid-width.
- b. At the head of the specimen in line with a vertical joint (if present)
- c. At mid height on the fixed edge.
- d. At mid height of the free edge, 100 mm in from the edge (if present)
- e. At mid width, where possible, adjacent to a horizontal joint (if present) (positive pressure zone).

A.4 Field of direct application

A.4.1 General

The results of the fire test are directly applicable to similar constructions where one or more of the changes listed below are made:

- a) Decrease in height
- b) Increase in the thickness of the cavity barrier
- c) Increase in the thickness of component materials
- d) Decrease in linear dimensions of boards or panels (if used) but not thickness
- e) Decrease in spacing of framing members
- f) Decrease in distance of fixing centres

A.4.2 Extension of width

The width of an identical construction may be increased if the specimen was tested at a minimum of nominally 3 m wide with one vertical edge without restraint. In the case of reduced size furnaces, no extension of width is possible.

Note: extensions of height and changes to the supporting construction are not really relevant to this situation as this annex explains the testing of a relatively specific end-use condition.

Annex B - Cavity barriers within walls e.g. masonry leaves

B.1 Introduction

One of the roles of cavity barriers is to prevent the spread of fire horizontally and vertically within the leaves of walls. The method essentially is similar to the linear gap seals method, but the use of a 'deep' supporting construction ('leaves') around the cavity barrier reduces the severity of the test. Tests need to be carried out in both the horizontal and vertical orientations to cover both orientations.

B.2 Configuration

With fire from within the cavity (from side 'A' in figures 2 and 4 below) the thermal exposure reduces as the depth of the 'leaves' (dimension X) increases. With fire from outside the cavity (from side 'B' in figures 2 and 4 below), then for narrow cavity barriers it becomes difficult if not impossible to evaluate the unexposed face for integrity and insulation. Consequently, all measurements on the unexposed face shall be as per EN 1363-1 with the exception that:

- Only the maximum insulation criteria shall be used for evaluating insulation
- Only the cotton pad and sustained flaming shall be used for evaluating integrity (i.e. the gap gauge is not used). Note: This follows the approach used in the linear gap seals test EN 1366-4.
- If the fire exposure is from side 'B' and if the width of the cavity barrier (dimension Y in figures 2 and 4) is less than 50mm then only the roving thermocouple shall be used for evaluating insulation i.e. no fixed thermocouples shall be used.
- If the fire exposure is from side 'B' and if the width of the cavity barrier (dimension Y in figures 2 and 4) is less than 50mm then the reduced size cotton pad from prEN 1366-3 may be used to evaluate integrity.

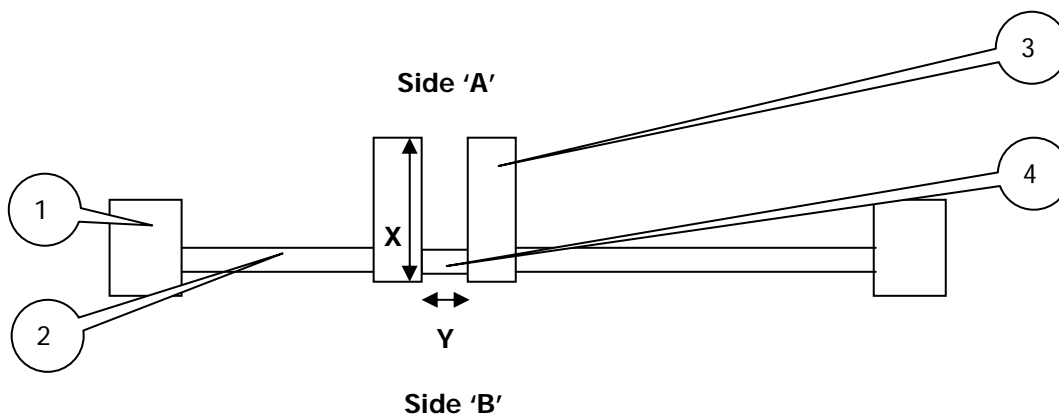

Figure 2 - test configuration for vertically oriented cavity barriers within walls (plan)

Key to figures 2 to 5

- 1 Test frame
- 2 Furnace closure for supporting construction and cavity barrier

- 3 Supporting construction (element ('leaves') into which cavity barrier is mounted). This could be gas concrete, dense concrete, masonry, calcium silicate board or plasterboard. For simplicity, this can be limited to gas concrete and calcium silicate. Suggested dimension for the depth of the leaves (dimension X) is 500mm.
- 4 Test specimen (cavity barrier)

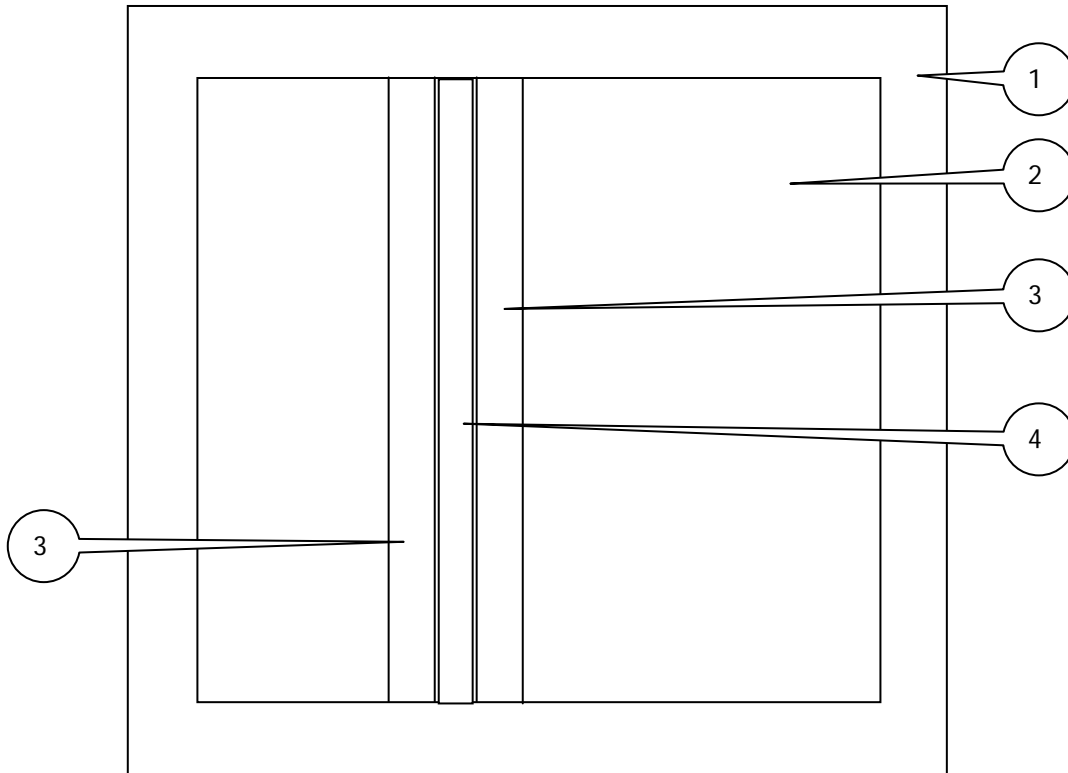

Figure 3 - test configuration for vertically oriented cavity barriers within walls (elevation)

The same principles and considerations shall be used when evaluating horizontal barriers inside a double-skin wall e.g. above an opening (see figures 4 and 5).

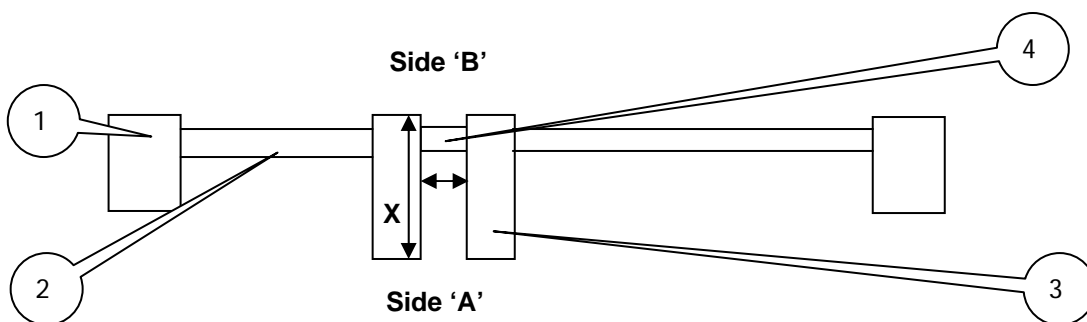

Figure 4 - test configuration for horizontally oriented cavity barriers within walls (elevation)

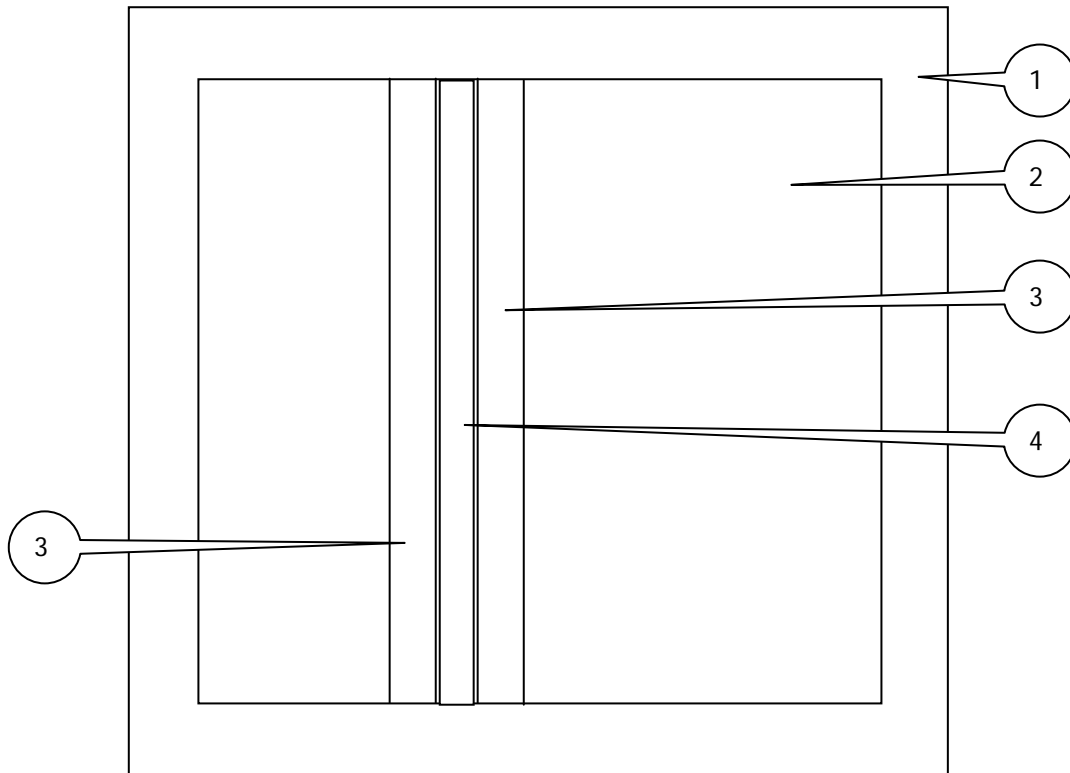

Figure 5 - test configuration for horizontally oriented cavity barriers within walls (plan)

B.3 Thermocouples for measuring the maximum temperature rise

Surface temperature measurements and the thermocouples shall be in accordance with EN 1363-1. The test specimen thermocouples shall be at the centre line of the cavity barrier. Figure 6 shows an example of thermocouple applications for a wall/floor.

If a potential weak point can be identified, additional fixed thermocouples shall be attached to this point, e.g. over a splice. Where it is impractical to attach thermocouples because of the nature of the surface of the cavity barrier (which may change significantly during the test period), careful use may be made of a roving thermocouple.

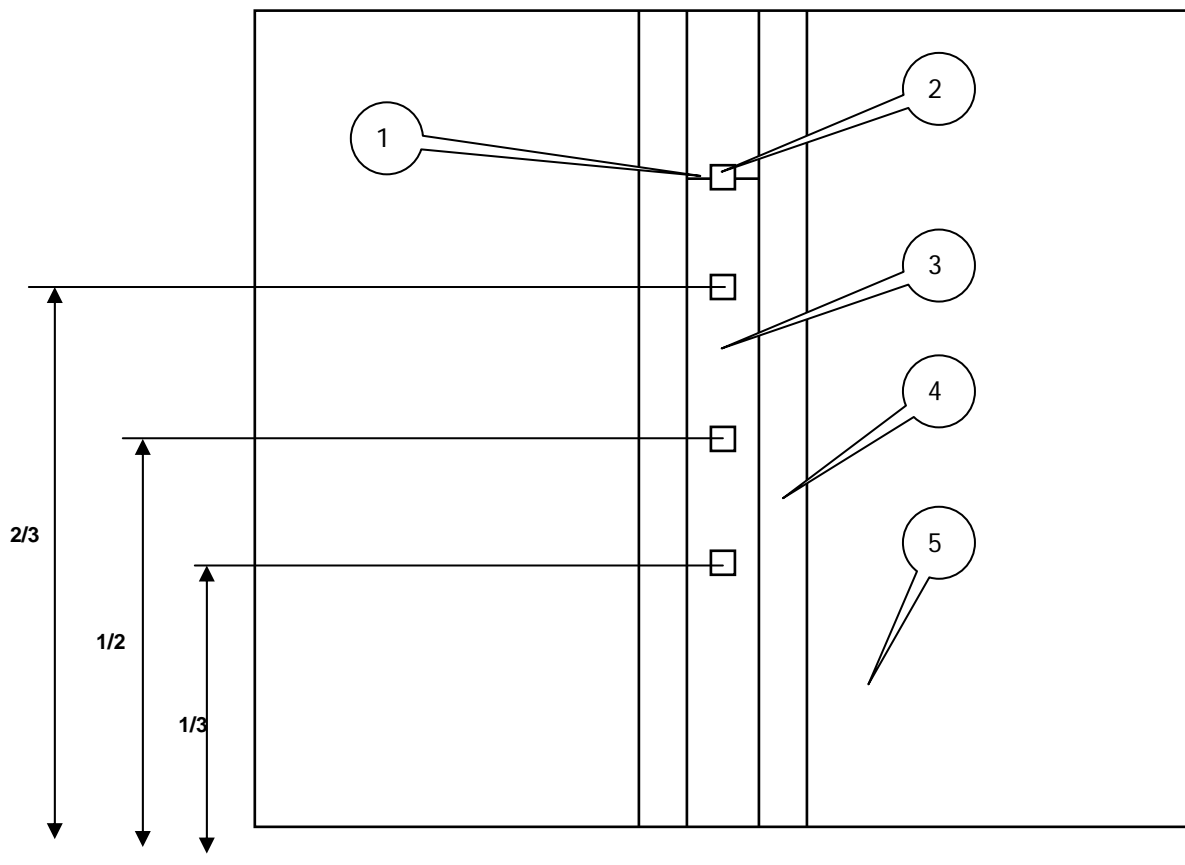

Figure 6 - unexposed face thermocouples for vertically oriented cavity barriers within walls (elevation)/horizontally cavity barriers oriented within walls (plan)

Key to figure 6

- 1 Splice (joint)
- 2 Splice thermocouple
- 3 Test specimen (cavity barrier)
- 4 Supporting construction (element ('leaves') into which cavity barrier is mounted)
- 5 Furnace closure for supporting construction and cavity barrier

B.4 Field of direct application

B.4.1 General

The results of the fire test are directly applicable to similar constructions where one or more of the changes listed below are made:

- a) Decrease in height for vertically oriented cavity barriers within walls/ decrease in length for horizontally oriented cavity barriers within floors
- b) Increase in the thickness of the cavity barrier
- c) Decrease in linear dimensions of barrier (height, width) but not thickness
- d) Increase in dimension of leaves (thickness and/or depth). NB this means that leaves smaller than 500mm deep (dimension 'X' in fig 2) can be used in the test. The figure of 500mm is just used for guidance and to provide leaves of suitable stability in the test.

B.4.2 Extension of height (vertically oriented cavity barriers within walls)

The height of an identical cavity barrier may be increased if the specimen was tested at a minimum of nominally 3 m high. In the case of reduced size furnaces, no extension of height is possible.

Note: extensions of width are not really relevant to this situation as this annex explains the testing of a relatively specific end-use condition.

B.4.3 Extension of length (horizontally oriented cavity barriers within floors)

The length of an identical cavity barrier may be increased if the specimen was tested at a minimum of nominally 3 m high. In the case of reduced size furnaces, no extension of height is possible.

Note: extensions of height are not really relevant to this situation as this annex explains the testing of a relatively specific end-use condition.

B.4.4 Supporting construction

The result of a test of a cavity barrier tested in a supporting construction as given in clause 7 or the test frame, is applicable to any other supporting construction within the same type that has a greater fire resistance (thicker, denser, more layers of boards, as appropriate).